

EM-167 DC MOTOR POSITIONING DRIVER

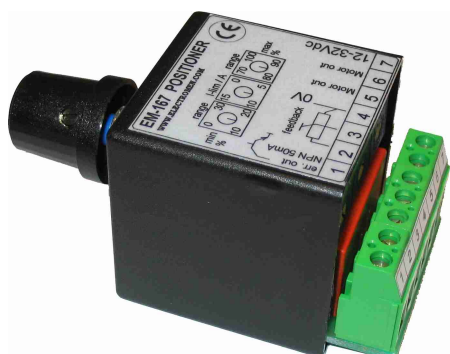

FEATURES

- small size
- pos. accuracy typ. $\pm 1\%$
- good efficiency $> 92\%$
- for motors 5-200W
- start- and stop-ramp
- overload protected
- adjustable current limit
- adjustable range

EM-167 is a compact positioning driver. The unit is equipped with its own set value potentiometer. EM-167 also has an inbuilt servo-amp. and power stage which is capable of driving a DC motor directly. It is suitable for driving a DC spindle motors equipped with feedback potentiometer. EM-167 is best suited for slow and medium speed systems with a transitional period of 2...30s (from end to end).

The current limit is adjustable and can be used to limit the torque of the motor. Current trip feature will shut down the driver in fault situation, if either current is on the limit for over 2s, or if it takes more than 30s to reach the set value. In fault situation the error output will be activated. Reactivation from the trip situation is done by applying a reverse control command.

Positioning is done by giving a set value using the EM-167 internal potentiometer. The driver compares the feedback value to the set value and starts to drive the motor towards the set value. When these values begin to approach each other the driver will slow down, and when the values are identical the motor stops. The operating range can be adjusted / limited from both ends with min. and max. adjustments. EM-167 is small-sized and easy to install. Due to its wide temperature range, the unit is suitable also for vehicle use. The power stage is equipped with self recovery overload and over current protection, but the use of an external fuse is recommended.

TECHNICAL DATA

Operating voltage	12-32Vdc
Idle current	< 40mA
Protections	overheat (self recovery) short circuit approx. 30A
Load capacity	4A continuous 8A 10s "on" 20s "off" 15A 3s "on" 30s "off"
Current limit	0-15A adjustable
Range adj.	0-30% low. & 70-100% up.
Accuracy	typ. $\pm 1\%$ of range
Feedback input	potentiometer 1...100kohm or voltage signal 0-5V
Ref. voltage pin-2	5V max. 15mA
Error out	NPN -open coll. 30V / 50mA
Efficiency	> 92%
Operating temp.	-20...60°C
Dimensions	39x39x50mm
Weight	approx. 85g

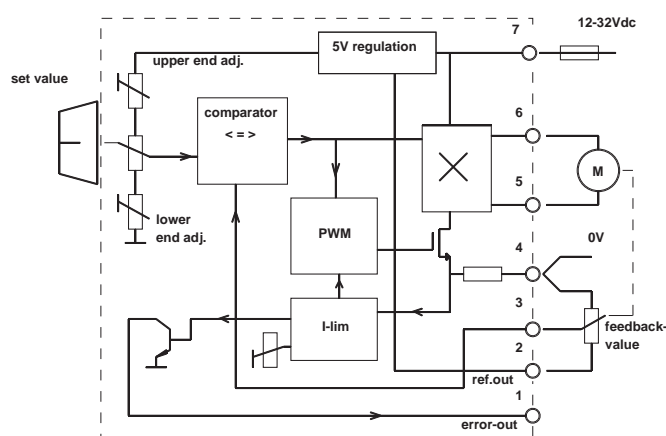

OPERATING INSTRUCTIONS EM-167

IMPORTANT !

Supply voltage must be filtered 12-32 VDC with less than 20% ripple.

Choose the fuse according to the application (max 15A).

Check the polarity before connecting.

ADJUSTMENTS

CURRENT LIMIT (MOTOR TORQUE)

First adjust the current limit equal to the rated motor current. After you get the application up and running, you can adjust the current limit to more suitable value for your application. In other words, use this adjustment to protect your motor and mechanics.

LOWER AND UPPER LIMITS (RANGE ADJUSTMENTS)

With these adjustments the range can be adjusted from both ends. Upper end from 70...100% of range and lower end from 0...30% of range.

For example, if the spindle motor range of movement is at maximum 0...100mm, using these adjustments the range can be reduced to 30...70mm at minimum.

TAKING ON DUTY

Connect the wiring and make sure that the current is adjusted according to the application (not too high!). Switch the power on. The system should now find the right position and follow the adjustment of the set value potentiometer.

If system only moves from end to end, or jam to the other end. Try to switch the motor wires (pin 5 & 6). Check also all other wiring.

If system is working o.k. but working direction is wrong, switch both, motor wires (pin 5 & 6) and the feedback potentiometer wires (pin 2 & 4) at the same time.

APPLICATION 1

Device connected to a spindle motor, feedback coming from spindle motor potentiometer.

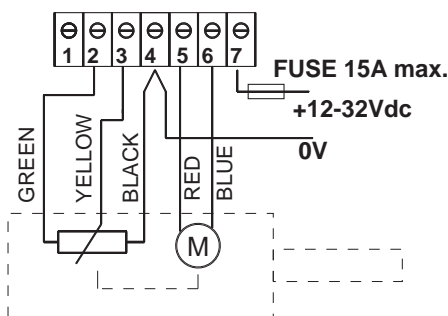

spindlemotor with feedback potentiometer LINAK LA.12

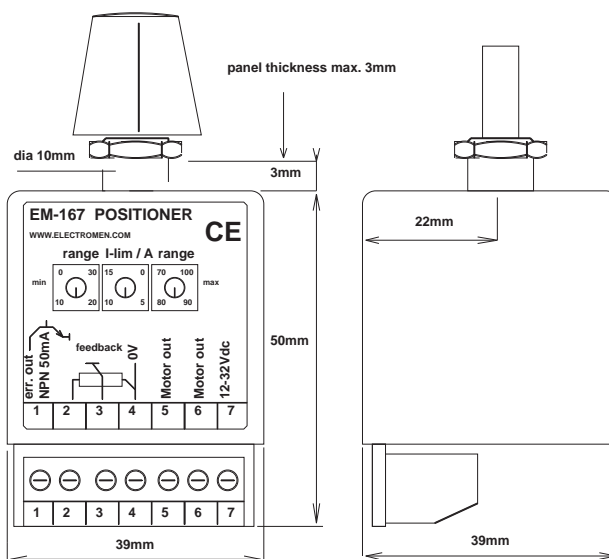

CONNECTION TERMINALS

1. error output, 30V / 50mA
2. 5V out, excitation for pot. max 15mA
3. feedback input
4. 0V, gnd
5. Motor
6. Motor
7. Supply 12-32Vdc

APPLICATION 2

EM-167 drives the angle of a table, the feedback is coming from 0-5V inclinometer.

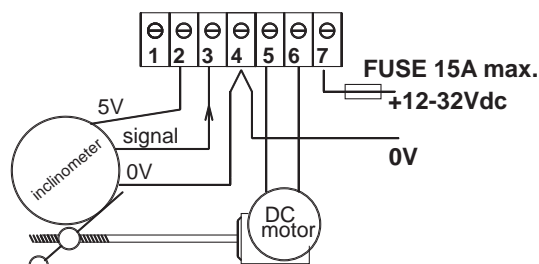

inclinometer Bosch 0280 122 201 + gearmotor

