

EM-115



FEATURES:

- Small size
- Four quadrant drive
- High efficiency >92%
- Motor range 50-500W
- Rail mounting base fittable
- Adjustable current limit
- Adjustable ramp

EM-115 motor control unit is designed for big permanent magnet DC-motors. The power control is done with PWM method (Pulse Width Modulation). This facilitates high efficiency and small temperature losses. Thanks to a high switching frequency the unit operates quietly. A battery or a filtered DC-supply will do as a power source.

The maximum output given by the unit depends on the installation. When operating at maximum power output sufficient air ventilation has to be taken care of. The unit operates in 4-quadrants so it drives and brakes in both directions. The braking is done with regenerative way feeding braking energy back to power supply. When a battery is not used as a power source the braking energy will be fed to the internal resistance of the motor. The motor rpm can be set either with potentiometer, trim or external voltage signal. The output acceleration ramp and current limit are set with trims, the current limit is indicated with a red LED. A load affecting the motor rpm can be eliminated with a compensation trim. The power stage is protected against voltage peaks, overload and temporary shortcuts. Even the incorrect polarity does not damage the unit as long as a fuse of recommended value is used.

TECHNICAL DATA:

Supply voltage	12...36 Vdc
Idle current	< 50mA
Recommended fuse	5-30A
Control potentiometer	1k..50k
Load capacity	25A RMS 50A mom. (5s)
Motor voltage	0-30V
Control voltage range	from 0-5V to 0-10V
Voltage loss /V	<1V when $I_m=25A$
Current limit	4..50A
Operating frequency	approx. 21kHz
Ramp time	0.3..10s
On / Off control	>4V "on" <1V "off"
Input impedance	pins 6,7 and 8 = 10kohm pin 9 = 100kohm
Efficiency	>92%
Operating temp.	-10..50 °C
Dimensions	107*107*45 mm
Weight	approx. 270 g

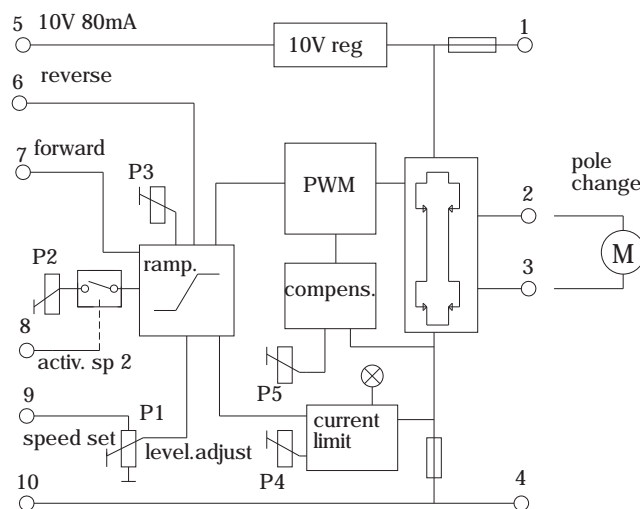

EM-115 OPERATING AND CONNECTING INSTRUCTIONS

IMPORTANT!

Check polarity before connecting!
Use filtered 12-36VDC (ripple <20%)
as operating voltage.

When motor current constantly exceeds 20A,
proper air ventilation must be taken care of.
Ambient temperature should not be over 50°C.

CONTROLS

P1-maximum level.
Use to set maximum level. This is also
the speed set for speed-1 in 2-step speed mode.

P2-speed-2
When using 2-step speed mode use P2 to
set speed-2.

P3-acceleration / braking ramp
Use ramp adj. to obtain smooth
starting and running. The right value
can be found just by testing the set.

P4-current limit
The operation of the current limit is indicated
by a red LED next to the trim. Use it to set the
desired maximum current to the motor, in other
words max. torque.

P5-compensation
Use this trim to compensate the load affecting
the motor rpm. Set the motor rpm to approx.
50%, adjust ccw until the motor starts to twitch,
then adjust carefully backwards till the twitching ends.

FUSE

The fuse type is ATO 5-30A, according to
the application.

Continuous rpm control,
set with pot.meter, adjust
range with P1.
Switch to forward.
Switch to change direction.

2-step speed mode
(run / positioning)
P1-speed1, P2-speed2
Activation with speed1
& speed2.

Continuous rpm control,
set with voltage, adjust
range with trim P1.
Reverse and forward with
TTL, CMOS or 0-24V signal.

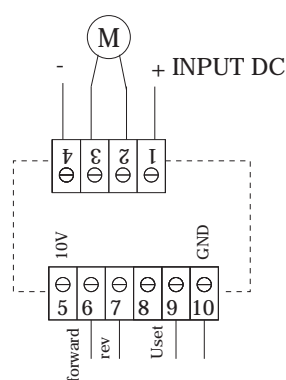
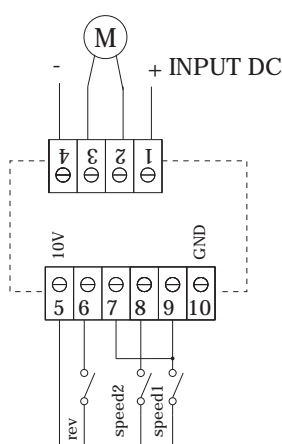
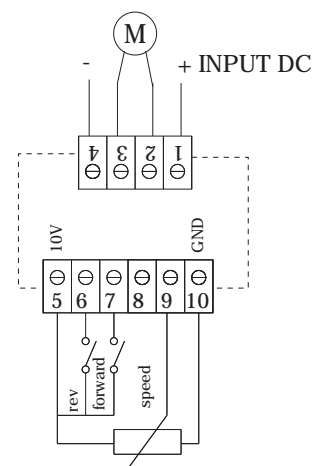

Forward, OFF 0-1V, ON 4-30V
Reverse, OFF 0-1V, ON 4-30V
Speed (Uset) 0-5V to 0-10V = 0-100%

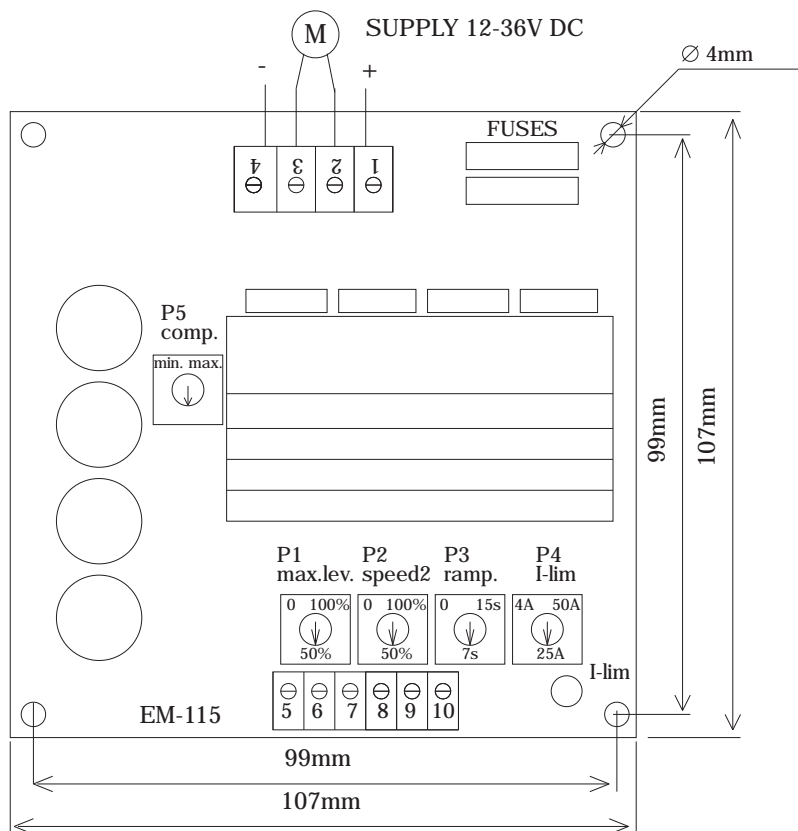

TERMINALS

1. Supply voltage 12-36V
2. Motor out +
3. Motor out -
4. Supply voltage 0V gnd
5. Control voltage approx. 10V 80mA
6. Reverse (master)
7. Forward
8. Speed-2 activation
9. Control input (U / pot.)
10. Signal 0V gnd

